

EG15* ... SERIES

SOLENOID GAS VALVES WITH 1/2" CONNECTION AND OPERATING PRESSURE UP TO 500 mbar

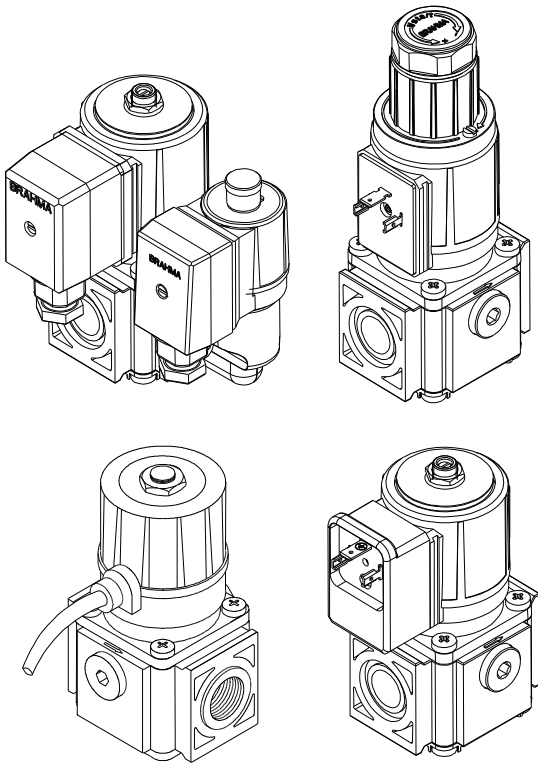

DESCRIPTION

This series of solenoid gas valves are of normally closed type, suitable for civil and industrial applications, supplied with alternate or direct current and inclusive of a wire-net filter on the inlet to avoid the entrance of dirt of > 1 mm.

Gas valves marked with "S" or "L" after reference type have direct current supplied coil, which permitted to make actions as silent as possible.

There is the possibility to have a fast opening or a slow opening valve (obtained by special hydraulic shock-absorber), with flow adjustment and fast opening initial flow adjustment and inlet and outlet pressure plugs.

Gas valves of this series, conforming to EN161, have a CE type Certificate (CE Reg. N° 63AQ0626) in accordance to European Directives 90/396 and 93/68.

- **EC-** type certification in accordance with the new European Gas Appliances Regulation (EU) 2016/426 (GAR);
- conformity to **EC** Low-voltage directive 2014/35/EU
- **AGA-** type certification (Certificate no. 4314 rev. 10) in accordance to standard requirements AS 4629-2005 (Incorporating Amdt 2);

TECHNICAL FEATURES

DN:	15
Class:	A
Group:	2
Supply voltage (1):	220-240Vac / 50-60Hz 110Vac / 50-60 Hz
Operating temperature:	-10°C / +60°C
Closing time:	≤ 1s (all versions)
Opening time:	≤ 1s (quick opening versions only)
Mounting:	vertical and horizontal
Body:	die-cast aluminium
Core hitch:	PG9

(1) Versions with different supply voltages are available.

DIRECTIONS FOR INSTALLATION AND MAINTENANCE

- This valve is a safety appliance and should not be modified. The manufacturer's responsibility and guarantee are invalidated in case the device is tampered with by the user.
- The applicable national regulation and European standards (Ex. EN 60335-1 and EN 60335-2-102) related to the electrical safety must be respected;
- Assemble the valve to the installation so that the arrow on the valve body has the same direction as the fuel flow.
- During the assembly of the valve to the installation piping, avoid twisting on the sheath and always use an hexagonal wrench to be fitted to the valve body.
- Make sure that no foreign matters have entered the valve body.
- Make sure that the max. fuel input pressure never exceeds the value appearing on the label.

- All operations (installation, maintenance, etc.) must be carried out by a qualified technician.
 - Before any connection operation, completely isolate the system from power supply (multi-pole disconnection). Place the system safely to avoid accidental switch-on and make sure there is no voltage. If the system is not switched off, there is a risk of electric shock.
 - During and after any operation (installation, maintenance, etc.), make sure that the type and code are the ones provided, check the correct functioning and the internal and external thickness of the valve.
 - In the event of a fall or impact, the valves must not be started, as safety functions may be compromised even if no damage is visible to the outside.
 - Faulty valves or damaged must be unplugged from power supply and cannot be used.
 - The valve has a designed lifetime* based on the endurance tests in the standard EN 161. A summary of the conditions has been published by the European Control Manufacturers Association (Afecon) (www.afecor.org). The designed lifetime is based on use of the valve according to the manufacturer's technical notes. After reaching the designed lifetime in terms of the number of burner startup cycles, or the respective time of usage, the valve has to be replaced by authorized personnel.
- * The designed lifetime is not the warranty time specified in the Terms of Delivery.

SOLENOID VALVES CONNECTIONS

It is possible to connect two valves with two fixing brackets and an O-ring to guarantee the sealing. The whole system is blocked by two screws, as shown in Fig. 1. This method permits to avoid the onerous use of threaded junctions.

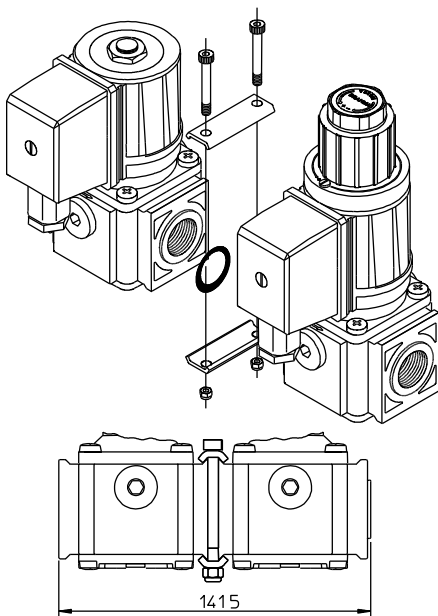

Fig. 1

SOLENOID VALVES WITH BY-PASS

All versions of EG25*... and EG30*... valves can be equipped with a by-pass valve (with orifice diameter 11 mm) directly fitted on the body. In this way it is avoided the installation of a separated by-pass valve.

Both to the main valve and to the by-pass one, flow is given from the same inlet gas pipe, even if they have different electrical controls.

By-pass valve can have fast opening, and can be with or without flow adjuster, but anyway inclusive of an inside rectification circuit, which permitted to use suitable attenuators, to make its actions as silent as possible.

DIRECTIONS FOR EG15*L... VALVES ADJUSTMENT

Flow adjustment for EG15*L...

To adjust the gas flow, you have to remove one of the two screws used to fasten the lag group (the not enamelled one, marked with 4 in Fig. 2) and rotate clockwise the whole group to reduce the flow or in the opposite direction to increase it.

Opening time adjustment

After removing the top protection, by rotating it counterclockwise, you have to act on the adjustment screw, marked with 1 in Fig. 2; by rotating clockwise, the opening time becomes longer, by rotating in the opposite direction, the opening time becomes shorter.

Quick release initial flow adjustment

After removing the top protection by rotating it counterclockwise, if you rotate clockwise the nut marked with 2 in Fig. 2, the initial release will be reduced; if you rotate the same nut counterclockwise, the initial release will be increased.

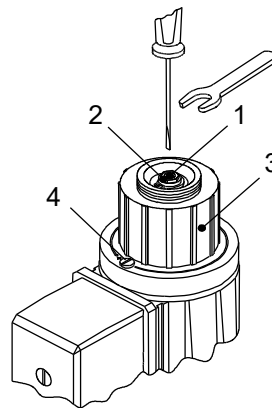

Fig. 2

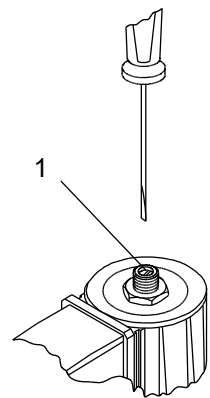

Fig. 3

DIRECTIONS FOR EG15*SR... VALVES ADJUSTMENT

Flow adjustment

Rotate clockwise the screw marked with 1 in Fig. 3 to reduce the flow, rotate in the opposite direction to increase the same.

OVERALL DIMENSIONS

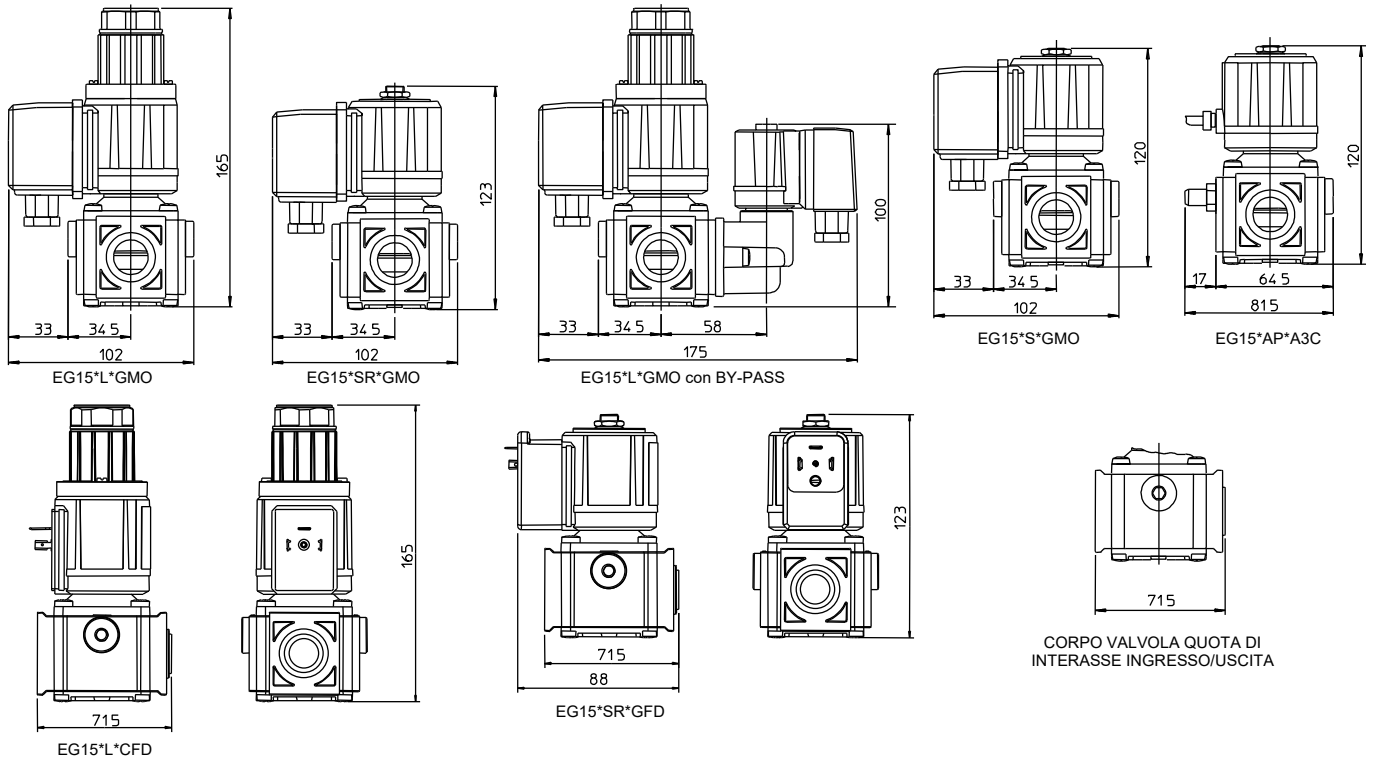

ELECTRICAL CONNECTION

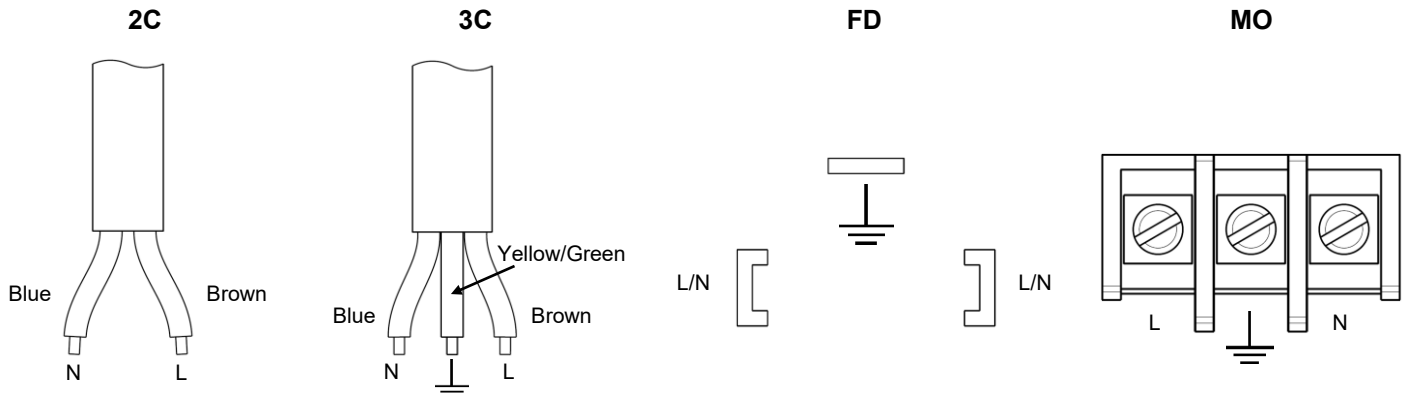

DIAGRAM

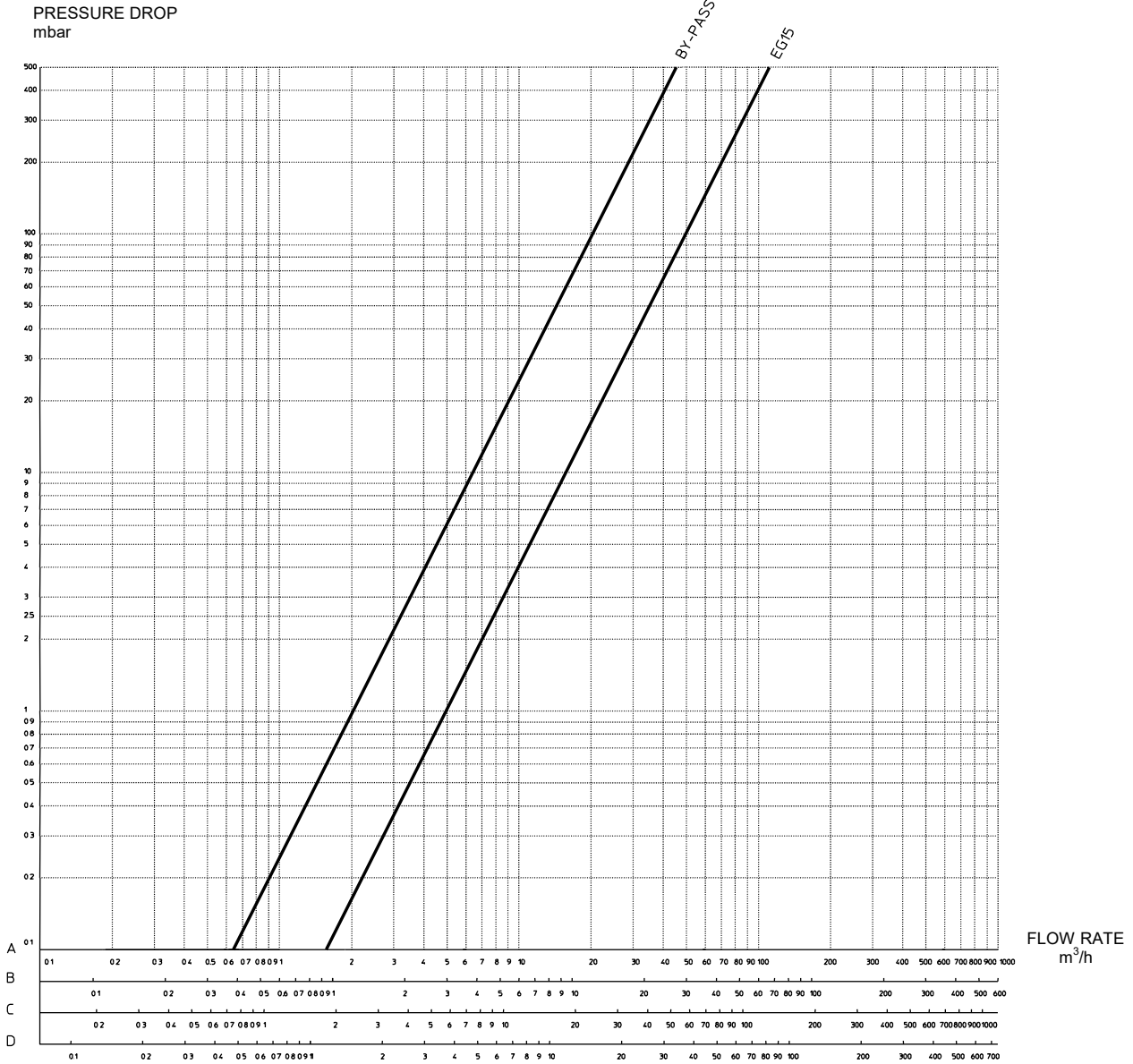

SUMMARY TABLE

Type	Operating pressure (mbar)	Orifice diameter (mm)	Connections	Weight (g)	Coil	Consumption (VA)	Consumption (VA)	Flow (m ³ /h gas with ΔP2.5mbar)
						220-240V	110v	
EG15*A	0 ÷ 500	15	G1/2"	820	BE6*A3C	22	18	8,0
EG15*A	0 ÷ 500	15	G1/2"	850	BE6*AFP	22	18	8,0
EG15*A	0 ÷ 500	15	G1/2"	852	BE6*AFD	22	18	8,0
EG15*S	0 ÷ 500	15	G1/2"	866	BE6*C3C	22	18	8,0
EG15*S	0 ÷ 500	15	G1/2"	896	BE6*CFP	22	18	8,0
EG15*S	0 ÷ 500	15	G1/2"	898	BE6*CFD	22	18	8,0
EG15*S	0 ÷ 500	15	G1/2"	918	BE6*G..	22	18	8,0
EG15*SR	0 ÷ 500	15	G1/2"	864	BE6*C3C	22	18	8,0
EG15*SR	0 ÷ 500	15	G1/2"	894	BE6*CFP	22	18	8,0
EG15*SR	0 ÷ 500	15	G1/2"	896	BE6*CFD	22	18	8,0
EG15*SR	0 ÷ 500	15	G1/2"	916	BE6*G..	22	18	8,0
EG15*L	0 ÷ 250	15	G1/2"	1027	BE6*G..	22	18	8,0
BY-PASS								
S	0 ÷ 100	11		275	BE7*GMO	8	6	3.2
SR	0 ÷ 100	11		285	BE7*GMOE	14	7	3.2

TYPE REFERENCE

EG15 * S R P * S R D * G FD 8 P D 220/240-50/60

Type _____

Opening Type (fast/slow) _____

Type	Description
A	Fast opening valve.
S	Fast, silent opening valve.
L	Slow, silent opening valve (this version is inclusive of flow adjuster).

Flow adjustment _____

Valve fitted with equipment for flow adjustment.

Pressure plug _____

Valve inclusive of pressure plug G1/4" size.

Valve fitted with BY-PASS _____

By-pass valve supply voltage and connections are the same of the main gas valve; therefore both "GMO" or both "GFD".

By-pass type _____

Type	Description
S	Fast opening.
SR	Fast opening with flow adjustment.

By-pass position _____

Type	Description
D	Right
S	Left

Supply voltage _____

Type	Description
110/50-60	110 Vac - 50/60 Hz
220/240-50/60	220/240 Vac - 50/60 Hz

Gas pressure switch position _____

Type	Description
D	Right
S	Left

Gas pressure switch type _____

Type	Description
P	Fixed setting
PR	adjustable setting

Test pressure point position _____

Type	Description
5	Outlet left.
6	Outlet right.
7	Inlet left.
8	Inlet right.

Connection type _____

Type	Description
2C	Connection with two core cable-IP65.
3C	Connection with three core cable-IP65.
FD	Connection with fast-on for plug DIN43650-IP65.(GFD IP40)
MO	Connection with terminal board-IP40.

Winding type _____

Type	Description
A	Supply in alternate current.
C	Supply in direct current.
G	Supply in alternate current, but valve operates in direct current thanks to an embodied rectification bridge. "MO" connection only. (For "MO" and "FD"connection versions only)



NOTES FOR PRODUCT DISPOSAL

The device contains electronic components and cannot therefore be disposed of as normal household waste. For the disposal procedure, please refer to the local rules in force for special waste.

ATTENTION --> Company Brahma S.p.A. declines any responsibility for any damage resulting from Customer tampering with the device.

BRAHMA S.p.A.

Via del Pontiere, 31
37045 Legnago (VR) - ITALY
Tel. +39 0442 635211 - Fax +39 0442 25683
<http://www.brahma.it>
E-mail: brahma@brahma.it

20/06/2023 Subject to amendments without notice