

Valve monitoring system

VDK 200 A S02

8.11

DUNGS[®]
Combustion Controls



Technical description

The VDK 200 A S02 is the compact valve monitoring system as per EN 1643 for automatic shut-off valves:

- Device operates independent of inlet pressure
- Test volume ≤ 20 l
- Setting possible on site
- The complete test procedure is defined
- Release time: max. 26 s
- Tightness or leaks are displayed by an LED
- Suitable for TRD systems
- Electrical connection at screw terminals via PG 11 cable entry

Fields of application

Valves according to EN 161 Class A

The VDK 200 A S02 may be used with any other valve whose tightness in counter-flow direction excludes by construction a leakage in flow direction.

The VDK 200 A S02 is suitable for all DUNGS valves according to EN 161 Class A.

For special model for H₂ applications, refer to data sheet 8.12.

Suitable for gases of gas families 1, 2, 3 and other neutral, technical burnable gases.

Approvals

EC type test approval as per EC Gas Appliance Directive:

VDK 200 A... CE-0085 AQ 0808

EC type test approval as per EC Pressure Equipment Directive:

VDK 200 A... CE0036

Approvals in other important gas-consuming countries.

Special design for the North American market with U_L, FM and CSA registration.

Specifications

Operating pressure	max. 360 mbar (36 kPa)		
Test volume	≤ 20 l		
Pressure increase by motor pump	35 - 40 mbar		
Rated voltage / frequency (admissible voltage range)	230 V AC -15% to -240 V +6%	50 Hz	
	For further voltages, refer to type overview		
Power requirements	During pumping time approx. 80 VA, in operation 20 VA		
Back-up fuse (provided by customer)	10 A fast-blow fuse or 6.3 A slow-blow fuse		
Fuse installed in housing cover, re-placeable	Microfuse T 6.3 L 250 V; IEC-127-2/III (DIN 41 662)		
Switching current Observe the starting current of the motor!	Operation output Fault output	Terminal 13: Terminal 14:	max. 4 A max. 1 A
Degree of protection	IP 40		
Ambient temperature	-10 °C to +60 °C		
Release time	10...26 s, depending on test volume and inlet pressure		
Interference time	32 ± 3 s		
Sensitivity limit	 50 dm ³ /h or 0.1 % of the burner heat load (> 500 kW) The VDK 200 A S02 can always be used with systems with a burner capacity < 500 kW or a test volume < 6 l. If the system has a burner capacity > 500 kW or a test volume > 6 l, the VDK 200 A S02 can be used only if the burner capacity is higher than the minimum burner capacity specified in the diagram.		
Switch-on duration of control	100 %		
Max. number of test cycles	15/h. Wait for at least 2 minutes after carrying out more than 3 consecutive test cycles.		
Installation position	vertical to horizontal, not upside down		

Defining the minimum burner capacity:

1. Determine the test volume (see page 5)
2. Test volume --> Inlet pressure curve
3. Inlet pressure curve --> Reading the minimum burner capacity
4. The VDK 200 A S02 can be used if the burner capacity is higher than the read minimum burner capacity.

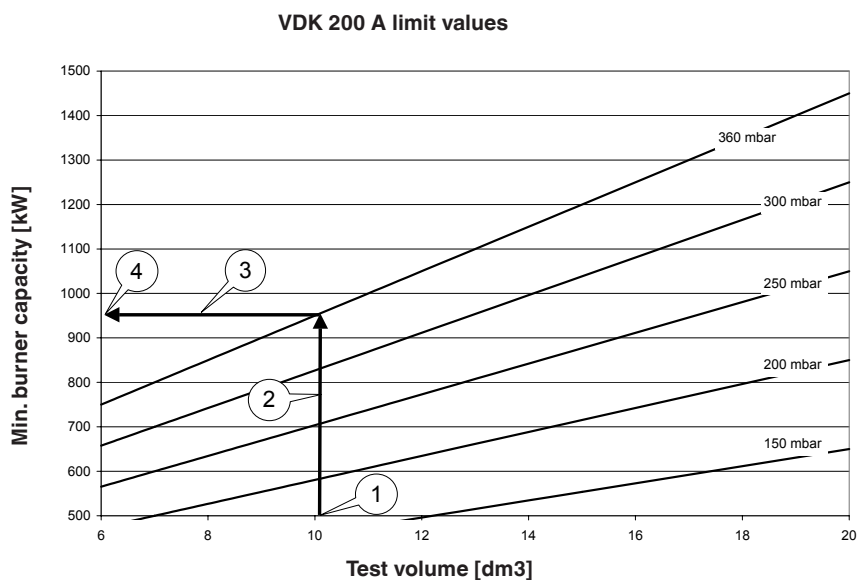

Program flowchart

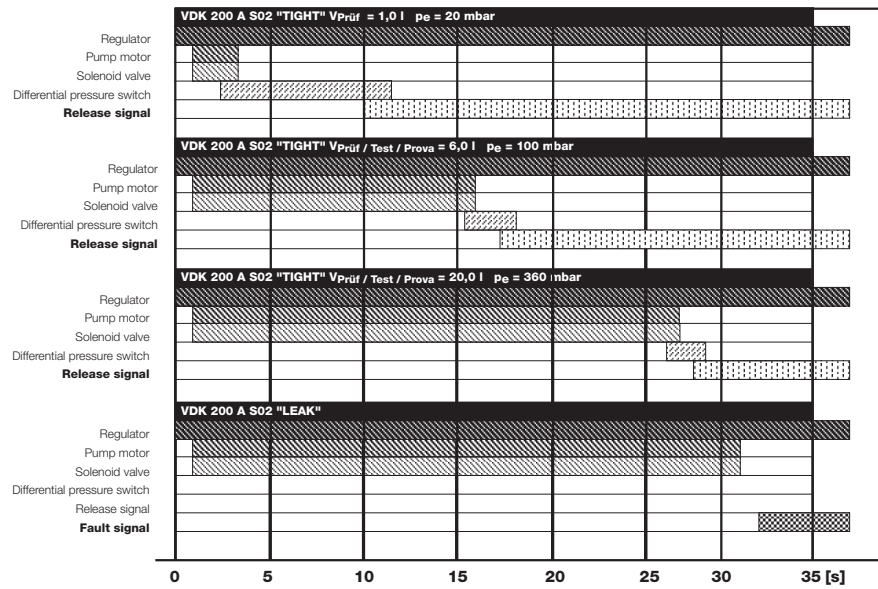

Program flowchart

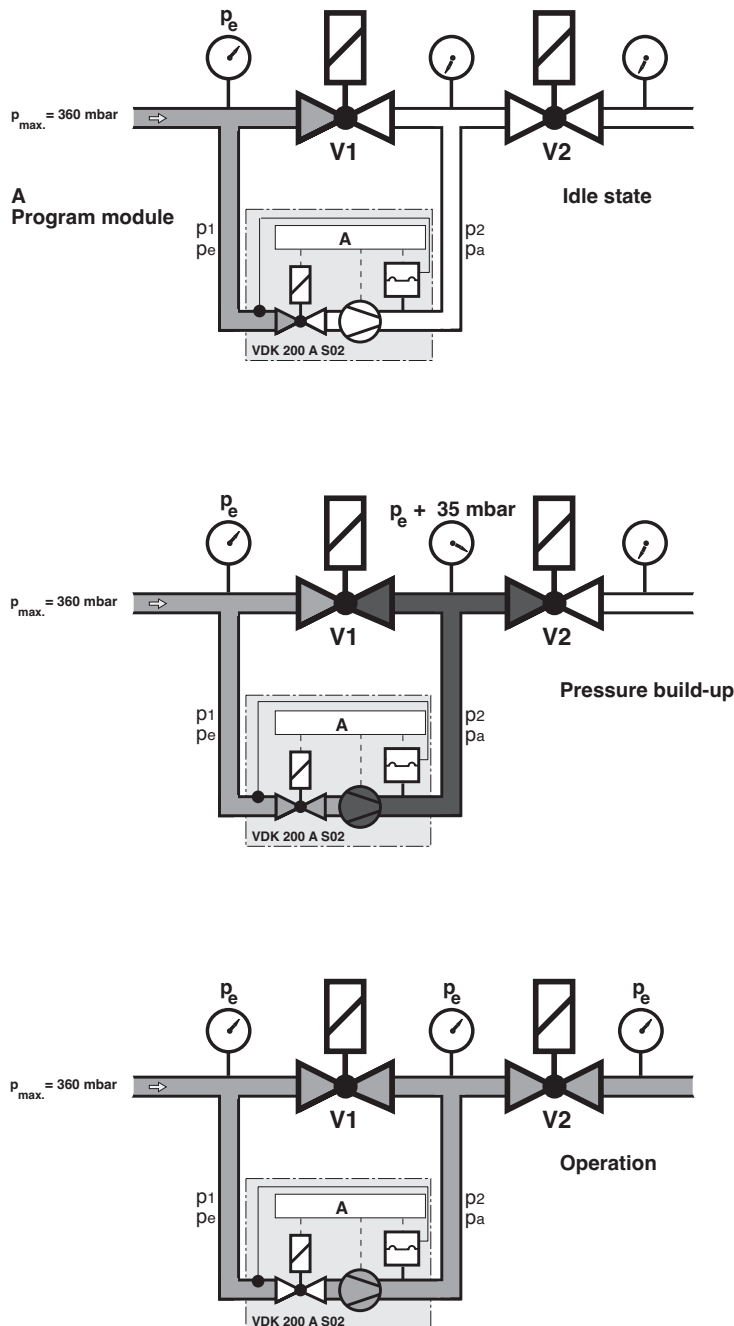

Idle state:

Valve V1 and valve V2 are closed.

Pressure build-up:

The internal motor pump increases the gas pressure in the test section by about 35mbar compared with the pressure arising on the inlet side at valve V1.

During the test period (pump period) the integrated differential pressure switch monitors the test section for leaks. When the test pressure is reached, the motor pump switches off (end of test period), and the yellow LED flashes until the contact is released. The release time (max. 26s) is dependent on test volume (max. 20l) and inlet pressure (max. 360mbar).

If the test section is leak-tight, the contact is released to the automatic burner control after 26s and the yellow LED comes on.

If the test section is leaky or if the pressure rise by +35 mbar is not reached during the test period (max. 26 s), the VDK 200 A S02 switches to fault. The red signal lamp lights as long as the contact is released by the regulator or thermostat (heat request).

An automatic restart is performed on short-term voltage failure during the test or in burner mode.

Operation:

Valve V1 and valve V2 are open, the internal valve of VDK 200 A S02 is closed.

Dimensions [mm]

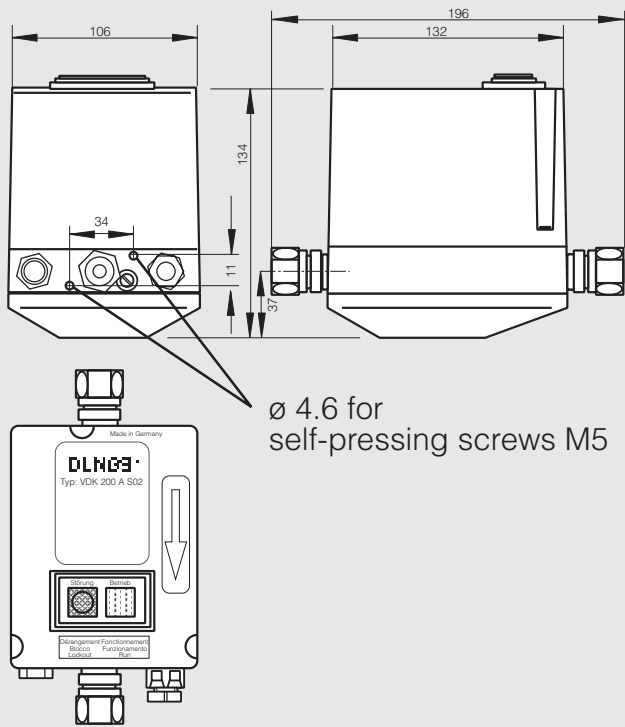

Electrical connection

VDK 200 A S02

Connection to screw terminals via PG* 11 cable gland (* = heavy-gauge conduit thread).

! Only use terminals 1, 3, 13 and 14. If you do not observe this instruction, it may result in personal injury or material damage.

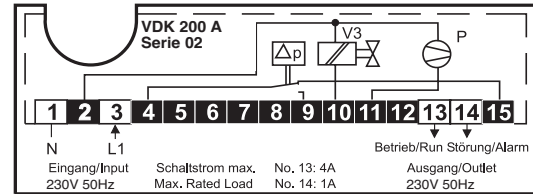

Functional description

The VDK 200 A S02 operates according to the pressure build-up principle.

The program module starts to function when heat is requested.

Test is performed depending on the burner functional procedure:

- Test **prior** to burner start or
- Test **during** pre-purge time or
- Test **after** burner shut-down

The VDK 200 S02 performs a self-test during a switching sequence.

Function principle

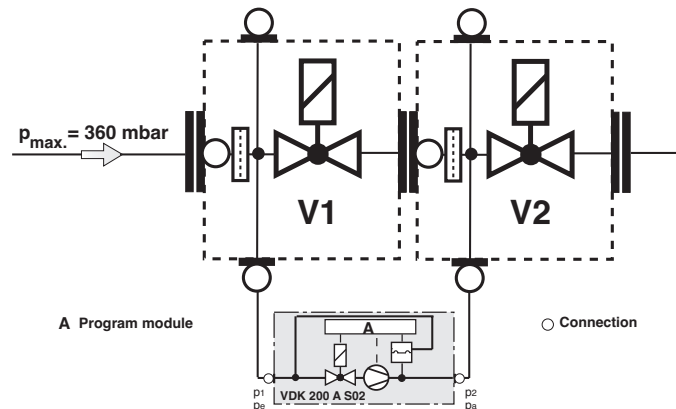

Startup

1. Check test section for leaks after assembly.
2. Start test by using temperature regulator and/or restart or by pressing the reset button on VDK 200 A S02.
3. **If the test section is tight**

Depending on the length of the test section and the residual pressure applied, the pumping time can be up to 26 s.

The release for the automatic burner control system is granted at the latest after approx. 26s - the yellow signal light illuminates continuously.

If the test section is leaky

The test pressure is not reached. The motor pump switches off, the red fault lamp lights up. Switch-through to the automatic burner control does not take place.

Functional check

By opening a screw plug p_2 (p_a) during the test period (pumping time), leakage can be simulated and a function check can take place.

Setting

The VDK 200 A S02 is preset at the factory. Setting the VDK 200 A S02 is possible on site. Setting is performed at the externally accessible setting screw. Apply varnish to the setting screw after startup. Keep strictly to the instructions.

Assembly

The VDK 200 A S02 must be connected to the DUNGS single valves (can be mounted on the right or the left) by means of two steel pipes (\varnothing 12 mm).

! If an exhaust gas valve is installed in the boiler, it must be open at the beginning of the test.

! In order to prevent functioning and tightness problems, we recommend to use solenoid valves according to EN 161 Class A.

! The connection lines between VDK 200 A S02 and the valves must withstand mechanical, chemical and thermal loads.

Using the VDK 200 A S02 at DUNGS individual solenoid valves .../5

We recommend the use of the connection kit, Order No.231 776, for mounting the VDK 200 A S02 on the valves Rp 1 1/2 to Rp 2 and or/ DN 40 to DN 50. We recommend the use of the connection kit, Order No.231 777, for mounting the VDK 200 A S02 on the valves DN 65 to DN 150.



The max. test volume of 20 l must not be exceeded.

$$V_{\text{Test}} = \text{Valve volume } V1 \text{ outlet} + V2 \text{ inlet} + \text{Volume of pipeline}$$

Determining test volume V_{Test}

Determine outlet-side volume of V1. Refer to table for Rp 3/8 to DN 200. Determine inlet-side volume of V2. Refer to table for Rp 3/8 to DN 200. Determine volume of intermediate pipeline section 3. Refer to table for Rp 3/8 to DN 200.

$$V_{\text{Test}} = \text{Volume Valve 1} + \text{Volume Intermediate pipeline section} + \text{Volume Valve 2}$$

Determining test volume V_{Test}

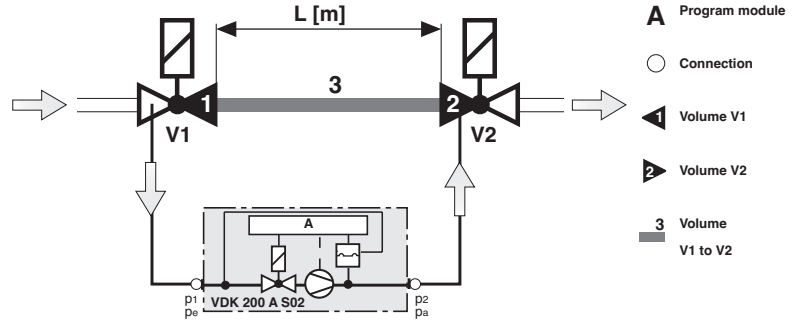

Rp / DN	Valve - Volume [l]		Test volume [l] = Volume V1 _{outlet} + V2 _{inlet} + Pipeline length							
	V1 _{outlet}	V2 _{inlet}	0,5 m		1,0 m		1,5 m		2,0 m	
	Rp	DN	Rp	DN	Rp	DN	Rp	DN	Rp	DN
Rp 3/8	0,01 l		0,06 l		0,11 l		0,16 l		0,21 l	
Rp 1/2	0,07 l		0,17 l		0,27 l		0,37 l		0,47 l	
Rp 3/4 (DN 20)	0,12 l		0,27 l		0,42 l		0,57 l		0,72 l	
Rp 1 (DN 25)	0,20 l		0,45 l		0,70 l		0,95 l		1,20 l	
Rp 1 1/2 / DN 40	0,50 l	0,70 l	1,10 l	1,35 l	1,70 l	2,00 l	2,20 l	2,65 l	2,80 l	3,30 l
Rp 2 / DN 50	0,90 l	1,20 l	1,90 l	2,20 l	2,90 l	3,20 l	3,90 l	4,20 l	4,90 l	5,50 l
DN 65		2,0 l		3,7 l		5,30 l		7,00 l		8,60 l
DN 80		3,8 l		6,3 l		8,80 l		11,30 l		13,80 l
DN 100		6,5 l		10,5 l		14,40 l		18,40 l		22,3 l
DN 125		12,0 l		18,2 l		24,3 l		30,50 l		36,6 l
DN 150		17,5 l		26,5 l		35,2 l		44,10 l		52,9 l
DN 200		46,0 l		61,7 l		77,4 l		93,10 l		108,9 l

— VPS 504
 - - - VDK
 DSLC

VDK 200 A S02 type overview / accessories / order details

Version		Order No.
VDK 200 A S02	230 VAC 50 Hz	211 222
VDK 200 A S02	110 VAC 50 Hz	211 224
VDK 200 A S02	220 VAC 60 Hz	211 225
VDK 200 A S02	240 VAC 50 Hz	211 229
VDK 200 A S02	120 VAC 60 Hz	211 927

Hydrogen version

VDK 200 A S02 H ₂ -version	230 VAC 50 Hz	214 445
VDK 200 A S02 H ₂ -version	220 VAC 60 Hz	222 166
VDK 200 A S02 H ₂ -version	120 VAC 60 Hz	222 747

For specifications, refer to
 Datasheet 8.12

Accessories / spare parts

Connection kit Rp 1 1/2 - Rp 2 DN 40 - DN 50		231 776
Connection kit DN 65 - DN 150		231 777
Appliance fuse link (5 pieces)		231 780

We reserve the right to make any changes in the interest of technical progress.

Head Offices and Factory
 Karl Dungs GmbH & Co. KG
 Siemensstraße 6-10
 D-73660 Urbach, Germany
 Telephone +49 (0)7181-804-0
 Fax +49 (0)7181-804-166

Postal address
 Karl Dungs GmbH & Co. KG
 Postfach 12 29
 D-73602 Schorndorf, Germany
 e-mail info@dungs.com
 Internet www.dungs.com